

# Fig. M733DR Cast Iron Globe Valves with Double Regulating Feature



## FEATURES AND BENEFITS

- Robust iron body materials for long service life
- Precise flow regulation
- Flanged with handwheel – easy to install and operate
- Positive flow control at all handwheel settings



## MATERIAL SPECIFICATION

Component	Material	Specification	
		BS EN	ASTM
Indicator Ring	Polymer		
Indicator	Polymer		
Gland	H T Brass	12164 CW721R	B138 C67500
Gland Packing	Graphite		
Stuffing Box	H T Brass	12164 CW721R	B138 C67500
Stem (50 to 100mm)	H T Brass	12164 CW721R	B138 C67500
Stem (125 to 200mm)	Stainless Steel	10088-1 X2 CrNiNo	17-12-2 A276-316L
Indicator Sleeve	Polymer		
Bonnet	Ductile Iron	1563 EN JS 1050	A536 80 55 06
Bonnet Gasket	Asbestos Free		
Disc Stem Nut	H T Brass	12164 CW721R	B138 C67500
Disc	Cast Iron	1561 EN JLI030	A126 CI B
Disc Coating	EPDM		
Body	Cast Iron	1561 EN JLI030	A126 CI B
Seat Ring	Bronze	1982 CC491K	

## DIMENSIONAL DRAWINGS

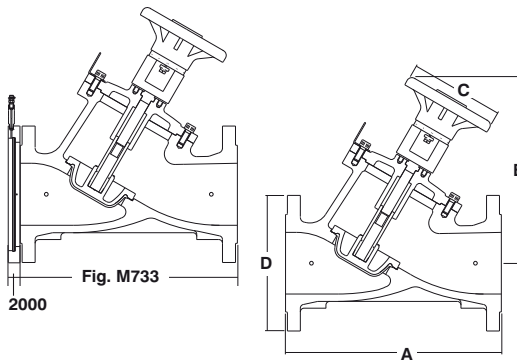

## PRESSURE/ TEMPERATURE RATING

16 bar from -10 to 120°C  
Note: The maximum temperature is determined by the EPDM elastomer coated disc.

## TEST PRESSURES (HYDRAULIC)

Shell: 24 bar  
Seat: 17.6 bar

## SPECIFICATION

Kitemarked to BS 7350:1990.  
Inside screw, non-rising stem.  
EPDM coated disc.  
Flanged to BS EN 1092-2 PN16.  
Fitted with regulating disc, double regulating device and indicator.



Use with M2000 PN16 to make Commissioning Set M2733

## DIMENSIONS AND WEIGHTS

Nom Size	mm	50	65	80	100	125	150	200
A	mm	230	290	310	350	400	480	600
B	mm	250	278	292	310	350	385	450
C	mm	166	166	166	166	250	250	250
D	mm	165	185	200	220	250	285	340
Weight	kg	15	21	26	37	65	82	139

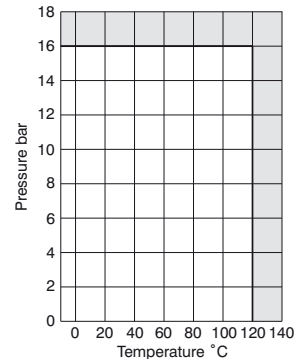

For Commissioning Valve Coefficients please refer to pages 49-51.

Every effort has been made to ensure that the information contained in this publication is accurate at the time of publishing. Hattersley Ltd assumes no responsibility or liability for typographical errors or omissions or for any misinterpretation of the information within the publication and reserves the right to change without notice.