

# Fig. 100CYL Gas Compression DZR - Lever Operated

## FEATURES AND BENEFITS

- Dezincification resistant
- Light, compact and easy to install and operate
- More resistant to damage during installation
- Sizes from 15 to 54mm
- Tested to BS EN 331:1998



## MATERIAL SPECIFICATION

Component	Material
Handle Sleeve	PVC Yellow
Hex-Nut	Dacromet Plated Steel
Handle	Dacromet Plated Steel
Packing Nut	Brass CW617N
Packing Gland	PTFE
Body	DZR Brass CW602N
Seats	PTFE
Ball	CW602N
O-Ring	NBR BS EN549 approval
Bonnet	DZR Bras CW602N
Sleeve	CW507L
Sleeve Nut	CW602N
Stem	DZR Brass CW602N

## DIMENSIONAL DRAWINGS

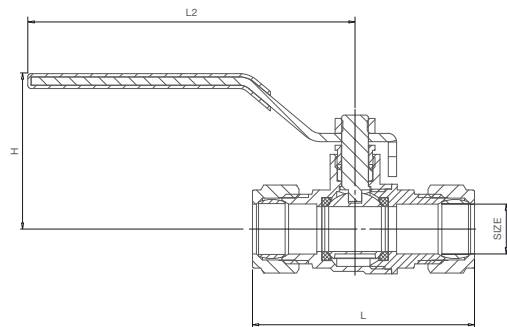

## SPECIFICATION

UK End Connection: Compression ends to BS EN 1254-2:1998.

Operator: Lever.

Specification: Quarter turn.

PTFE seats and stem seal.

Tested by GL Industrial Services and complies with the essential requirements of BS EN 331:1998.

## PRESSURE/TEMPERATURE RATINGS COMPRESSION

### NON-GAS APPLICATION

Temperature °C	-10 to 30	110
Pressure bar	16	5

### GAS APPLICATION

Temperature °C	-10 to 60
Pressure bar	5

Intermediate pressure ratings shall be determined by interpolation

## DIMENSIONS AND WEIGHTS

Nom Size	mm	15	22	28	35	42	54
L	mm	66.5	80	92.5	104.5	122	141
L2	mm	98.5	98.5	125	140	140	165
H	mm	47	51	63	78	83.5	97.5
Weight	g	212	368	608	1007	1545	2538

Every effort has been made to ensure that the information contained in this publication is accurate at the time of publishing. Hattersley Ltd assumes no responsibility or liability for typographical errors or omissions or for any misinterpretation of the information within the publication and reserves the right to change without notice.