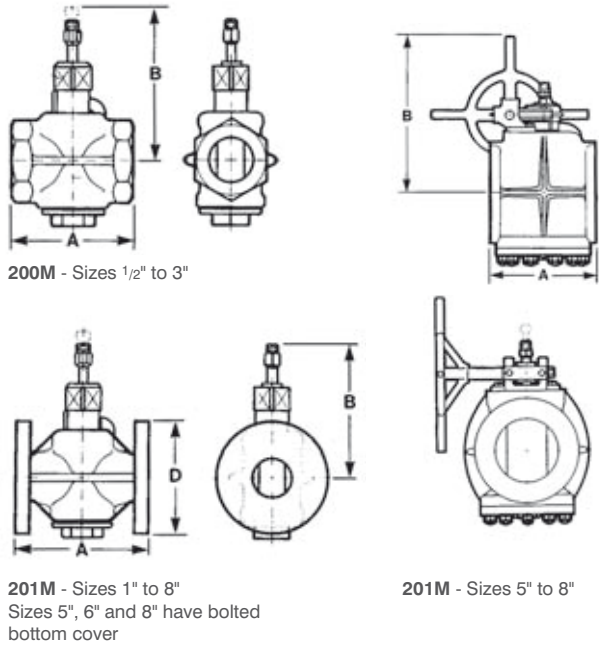

Fig. 200M (Screwed), 201M (Flanged)
Cast Iron HNH-Milliken - Short Pattern, Full Bore

FEATURES AND BENEFITS

- Sealing compound effects a completely leak tight seal.
- When open - presents a straight through passage in line with pipeline
- Stops flow after 90° turn

DIMENSIONAL DRAWINGS



DIMENSIONS AND WEIGHTS

Dimensions 200M and 201M

Nom Size	mm in	15 1/2	20 3/4	25 1	32 1 1/4	40 1 1/2	50 2	65 2 1/2	80 3	100 4	125 5	150 6
A (200M)	mm	81	88	106	111	117	152	165	187	-	-	-
A (201M)	mm	-	-	121	111	117	178	190	203	229	254	267
	in	-	-	4 3/4	4 3/8	4 5/8	7	7 1/2	8	9	10	10 1/2
B	mm	-	-	108	124	127	197	206	254	270	299	327
D Flanged PN16	mm	-	-	115	140	150	165	185	200	220	250	285
D Flanged ANSI 125	in	-	-	4 1/4	4 5/8	5	6	7	7 1/2	9	10	11
Wrench		G	G	G	J	J	L	L	O	P	P	Q
Weight (200M)	kg	0.8	1.2	2.1	2.6	3.1	6.0	8.8	14	31	-	-
Weight (201M)	kg	2.7	2.7	3.9	4.6	5.7	10	13	19	39	58	77

DETAILS OF TAPPED HOLES

The close proximity of the flange to the body does not allow room for all bolt holes to be drilled through. These holes are drilled and tapped as follows:

Valve size	Tapped
100 and 125mm	M16
150 to 200mm	M20

Dimensions 201MG (with gear unit)

Nom Size	mm in	125 5	150 6	200 8
A	mm	254	267	292
	in	10	10 1/2	11 1/2
B	mm	381	473	533
D Flanged PN16	mm	250	285	340
D Flanged ANSI 125	in	10	11	13 1/4
Weight	kg	72	95	167

Every effort has been made to ensure that the information contained in this publication is accurate at the time of publishing. Hattersley Ltd assumes no responsibility or liability for typographical errors or omissions or for any misinterpretation of the information within the publication and reserves the right to change without notice.